

EUROSYSTEM[®]

2000

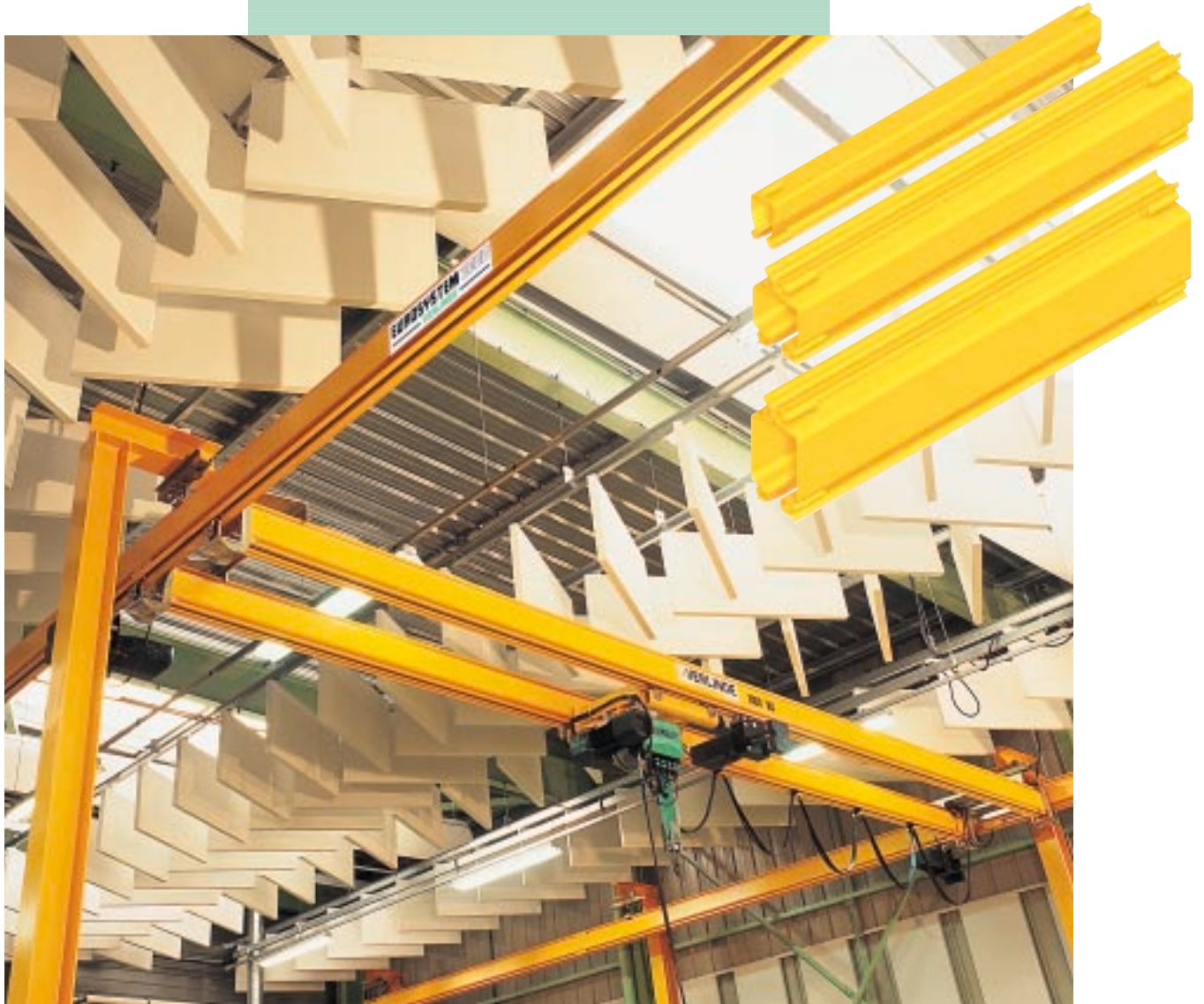

**Light crane
system
from 125 to 2000 kg**



2, boulevard de l'Industrie - B.P. 59 - 28501 Vernouillet cedex - France

Phone : (33) 02 37 38 95 95 - Fax : (33) 02 37 38 95 99

Internet : www.verlinde.fr

Ref: JV 02 2002 532 UGB

1 EUROSYSTEM 2000 is available in 3 different profiles, which are determined by load capacity and the distance between suspension points.



UKA 20

UKA 30

UKA 40

Load capacity from 125 to 2000 kg according to profile type. The system is based on a special hollow profile, which is manufactured in cold formed metal sheet in order to obtain an extremely smooth and regular surface. The closed structure of the profile makes it possible to keep the inside of the running surface clean.

2 End plates :

- To prevent bending or distortion of the hollow profile.
- End stops for manual or motorized trolleys.
- To prevent dust collection on the inside surface of the profile.

3 Lifting functions are fulfilled by EUROCHAIN hoists with a variety of load capacities and lifting speeds.

These hoists can be equipped with either a manual or an electric trolleys for horizontal movement.

- Choices include load capacity from 125 to 2000 kg.
- Lifting height from 3 meters (standard) and up to 30 m.
- One or two lifting speeds of 2, 4, 8, 4/1, 8/2,...
- A number of optional features are available for these hoists (Remote control system, hook version and stainless steel chain, etc...).



EUROCHAIN VL

veco EUROSYSTEM 2000

or how to easily h

EUROSYSTEM 2000 offers a variety of possibilities

- Monorail tracks.
- Runways.
- Single girder cranes.
- Double girder cranes.
- Simple or complete circuit systems with direction-changing system either by switches or turnables.

Outstanding advantages

- Reduced headroom (increased working height).
- Easy movement thanks to excellent rolling friction coefficient.
- Easily extendable monorail tracks, runways, circuits, thanks to the modular system design.
- Installation and fixation is done by simple bolting.
- A variety of types of fixation that can be adapted to all types of structure (steel beams, wood, concrete, etc...).

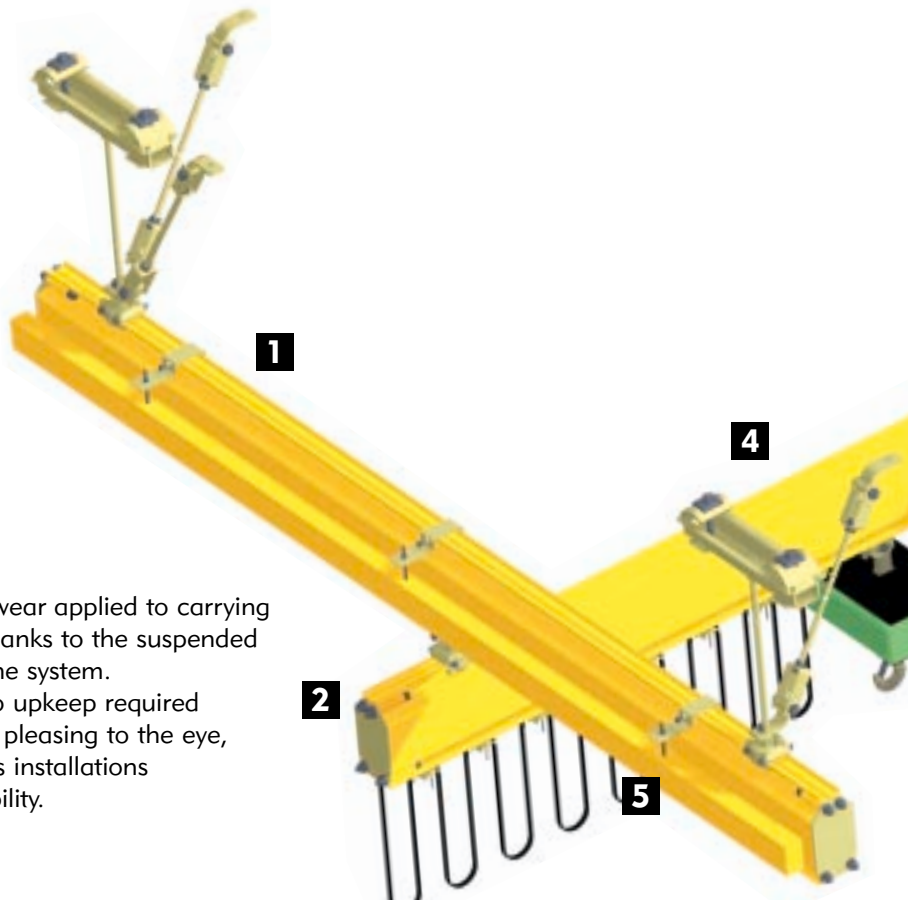

- Less force/wear applied to carrying structure thanks to the suspended design of the system.
- Almost zero upkeep required
- Esthetically pleasing to the eye, harmonious installations
- Great flexibility.

Suspended or short headroom single girder crane

Load capacity from 125 to 1600 kg gives a practical solution for the handling needs in large facilities. EUROSYSTEM 2000 components are compact, offering an efficient use of space.

Suspended on trolleys, the crane beam travels along the length of the runway profiles manually or electrically. For longer spans, rigid connections optimize the beam travelling.

EUROSYSTEM 2000 profiles are also used as runways and may be fixed to the ceiling with adapted suspension system .

EUROSYSTEM[®] 2000

handle light loads

Suspended double girder crane or short headroom constructions

Load capacity from 125 to 2000 kg. For heavier loads, the EUROSYSTEM 2000 double girder crane is suitable for all your lifting and handling needs.

The design of the hoist trolley that travels between the profiles allows for exceptionally low height requirements.

The movement of this crane is made even smoother thanks to trolleys fitted with nylon rollers in contact with the inside surface of profiles.

travels is achieved either by pushing the load or through the use of a motorized trolley for larger and heavier loads.



4 Any crane and monorail track can be equipped with trolleys in order to provide travel of the hoists, or of the crane.

In order to satisfy your needs, we offer a very complete range of trolleys:

- Manual trolleys (UKA 20, 30 & 40) single, double or articulated.
- Motorized trolleys types UKTD (UKA 30 & 40) single, double or articulated.

An outstanding rolling friction coefficient guarantee smooth low-noise movement. Trolleys are made of nylon wheels, and the contact surface inside the profiles is reduced.

Thanks to the modular design of the EUROSYSTEM 2000 light crane system, it is possible to motorize a manual trolley later on.

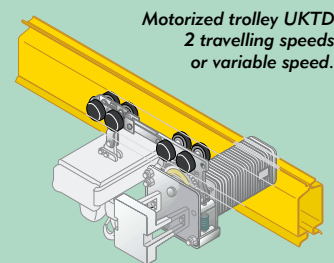

5 Power-feed systems built-in or outside the profiles are available.

6 The assembly of the profiles is done with connection bolts and connection parts with adapted locating features.

7 The suspensions allow fitting the light crane system to the support structure. Several different types of suspensions are available according to the type of profile used, and the type of structure supporting the system:

- Side or vertical suspensions, short or extended.
- Suspension for straight ceiling or I-beam.
- Suspensions for UKA 20, 30 or 40.

Thanks to their design (self-locking parts, articulated structure, easy adjustments, etc.) EUROSYSTEM 2000 suspensions allow greater flexibility when being installed, prevent internal pressure and balance any possible irregularities of the support structure.

8 All our suspension systems are fitted with threaded rods for the precise adjustment of your EUROSYSTEM 2000 equipment (extensions are also available).

EUROSYSTEM 2000 offers a unique modular concept

ESM type monorail available in a straight and a curved style.



Combining the various components of **EUROSYSTEM 2000** make it easy to adapt to your production line.

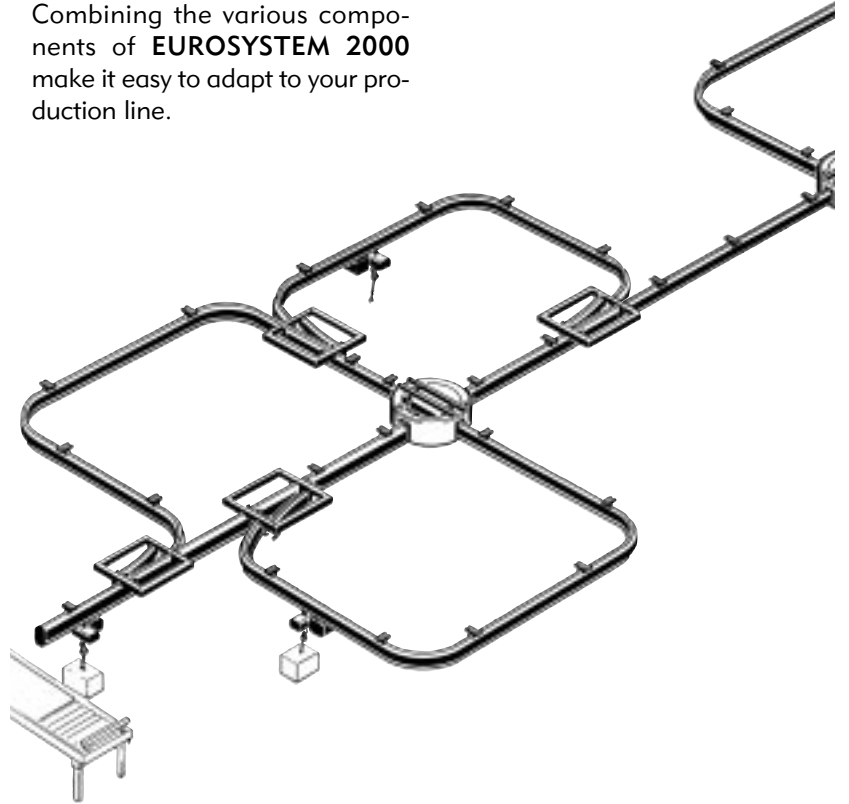

EUROSYSTEM profiles also exist as jib arms

EUROSYSTEM 2000 wall-mounted jib crane

Load capacity :

125 - 250 - 500 - 1000 - 1600 - 2000 kg.

Span :

From 2000 to 6000 mm according to model.

EUROSYSTEM 2000 mounting bracket gives the ideal solution for work stations located near a wall or vertical structures. It can be used over a sector measuring 180° with a radius between 2 and 6 meters.

They are the complement you can't do without for rolling cranes, for the overall efficiency in a workshop.

They make each production point independent and ultra-efficient.

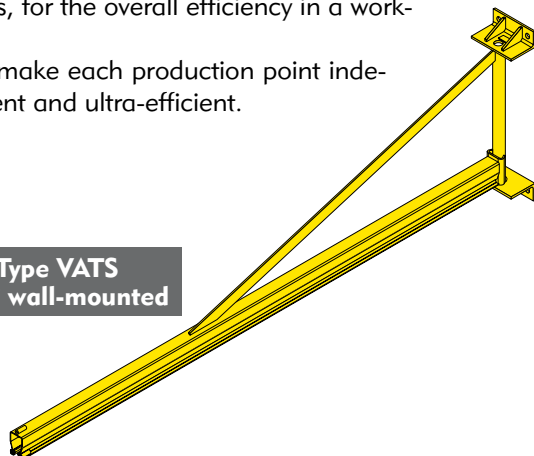

Type VATS
180° wall-mounted

EUROSYSTEM 2000 pillar jib crane

Load capacity :

125 - 250 - 500 - 1000 - 1600 - 2000 kg.

Span :

From 2000 to 7000 mm according to model.

EUROSYSTEM 2000 column-mounted pillar jib cranes are necessary when there is no other appropriate support near a work station.

It allows load handling over an area measuring 270° and a radius measuring between 2 and 6 meters.

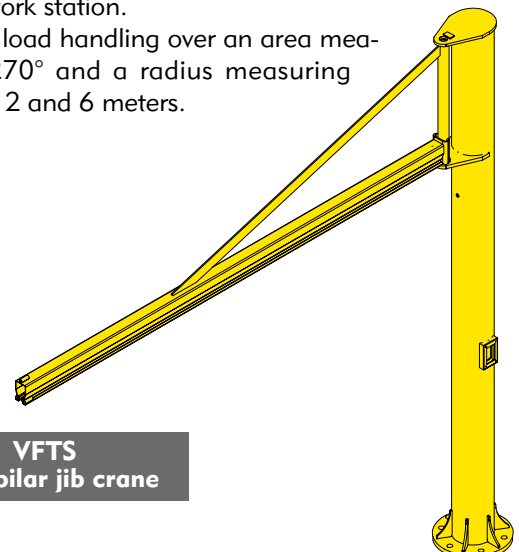

VFTS
270° pilar jib crane